



# Break-Away Couplings Technical Information

**TODO**

**Gardner**  

---

**Denver**

## Break-Away Couplings – Product Range

The TODO Break-Away Coupling range is an essential part of the work place safety equation. As well as ensuring the environment is protected from potentially hazardous spills, the Break-Away Couplings are designed to prevent pull away/drive away incidents thereby eliminating potential spills, and protecting the loading system / hose in the process.



### NGX Series – Next Generation Safety Break-Away

Faster – Smaller – Lighter

The NGX Series Break-Away is a new product from TODO and dramatically improves the performance of the first generation with a large reduction in pressure drop, overall length and weight, making it the market leader in performance Break-Away products.



### NGXM Series – Next Generation Marine Break-Away

The NGXM Series Marine takes the dramatic improvements of the NGX Series and applies break force limitation, so that it will only break when subjected to an overload in straight-pull force, rendering any tidal or wave movement redundant.



### BCR Series – Collar Release Break-Away

The Collar Release Break-Away is specifically designed for loading arm protection, avoiding potentially dangerous pull away situations. The Collar Release design ensures a safe break point when the predetermined working envelope is exceeded. This ensures that there is no over-extension of the loading arm.

## Break-Away Couplings – Overview

The TODO Break-Away Coupling product range has been designed with safety in mind. Its main purpose is to prevent spillage of potentially hazardous substances and damage associated with drive away / pull away accidents when loading / unloading via loading arms, hoses or rigid pipework systems.

TODO provides a range of products to suit the needs of the application; whether the requirement is to protect a loading arm, high performance or a simple reliable break point in the line, we have the product to solve the problem.

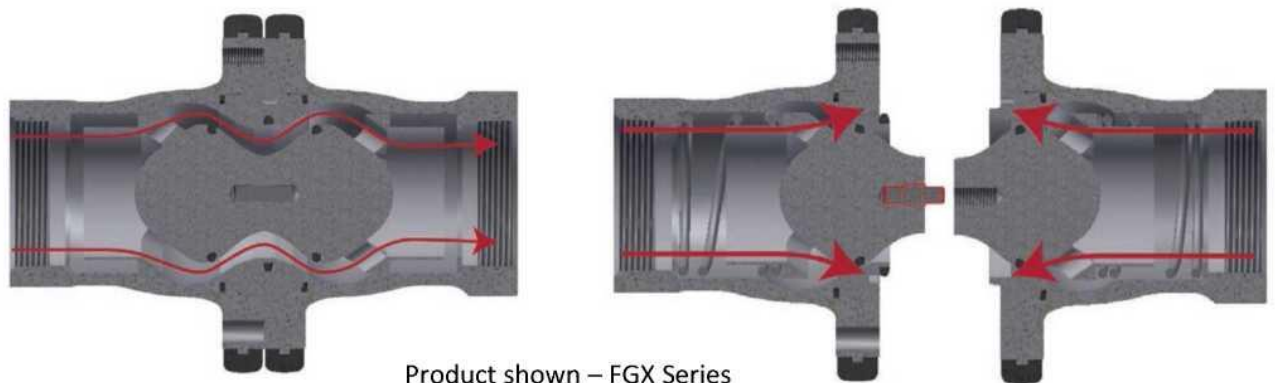

In the coupled position, the Break-Away allows the liquid or gas being transferred to flow normally with minimal flow restrictions. The two halves are sealed by the O-ring in the piston seat, ensuring zero leakage during transfer.

When subjected to an overload in force, the break pin or retaining collar will shear, releasing the two halves. This action activates the spring-loaded pistons and closes both ends, sealing tight. The Break-Away will contain the pressure and liquid / gas until the line is de-pressurised and/or drained. At this point the Break-Away can then be inspected for damage and a repair kit installed, allowing the Break-Away to return to a fully functional state, and then recoupled as a full product via new break pins or the retaining collar, ready to be used once again.

### Benefits of TODO Break-Away Couplings

- High quality products – TODO uses only the highest quality materials in the manufacture of its products
- Excellent reliability
- Simple service and maintenance
- Minimal product loss on disconnect
- Easy to reset on site



# TODO

## NGX Series – Next Generation Break-Away

The TODO NGX Series Break-Away is a high performance safety product, offering the best flow rate versus pressure drop relationship on the market. It's also smaller and lighter, meaning much simpler handling, service and maintenance.

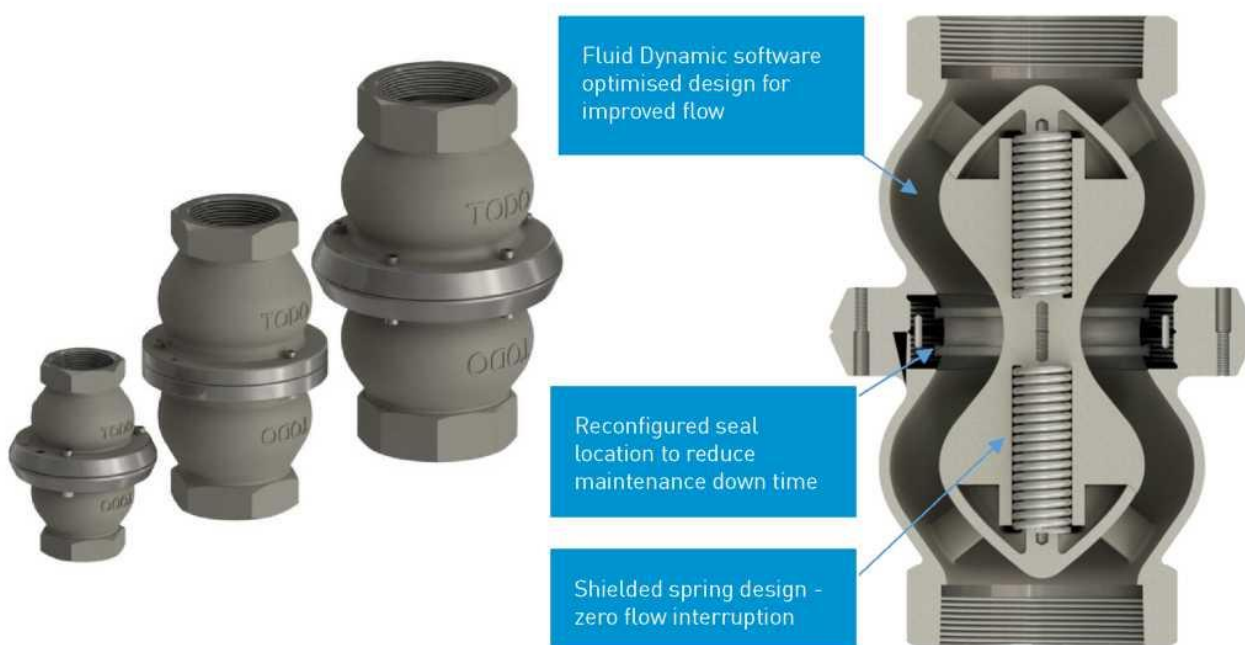

Still designed to be a reliable break point in the loading / unloading line, the NGX series speeds up customer deliveries through its optimised flow design throughout. The spring is totally encapsulated whilst coupled, and the piston seal has been relocated to greatly ease servicing and maintenance.

### New Features:

- **Low Pressure Drop** – The internal and external geometry has been designed with flow in mind – the flow path now has limited obstructions and heavily reduced turbulent flow areas, offering highest flow rates on the market today.
- **Lighter** – The material thickness now has uniformity in all possible areas, maintaining the same safety factor of its predecessor
- **Smaller** – The NX range had been designed with the operator in mind
- **Sealing** – The seal locations have been optimised

### Benefits:

- Faster loading/unloading due to the optimised flow rates offered
- Simple to retrofit onto Loading Arms
- Easier to handle when loading / unloading
- Reduced maintenance due to internal redesign and new seal placement
- Easy to reset on-site, saving time, saving money

## Technical Data

Sizes: 2" (DN50) - 6" (DN150)

Materials: Aluminium, Stainless Steel (316L)

Seals: Viton® (FKM) as standard.

Wide range of other materials to suit many applications

Working Temperature: -20°C (-4°F) - +80°C (176°F)

Working Pressure: Up to 40 bar (580 psi)

Test Pressure: Up to 60 bar (870 psi)

Possible Break Angle: 0-90°

End connections: NPT / BSP / PN10/16 / PN25/40 / ANSI 150 / ANSI 300 / TTMA

Others available on request

Viton® is a registered trademark of DuPont Performance Elastomers

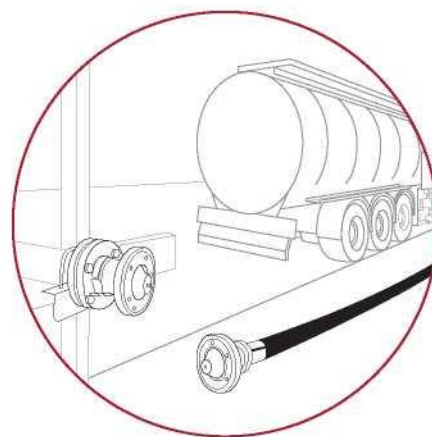
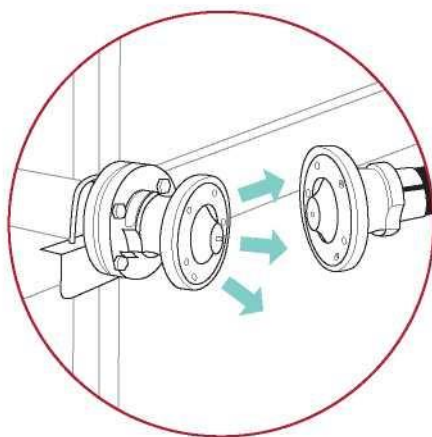
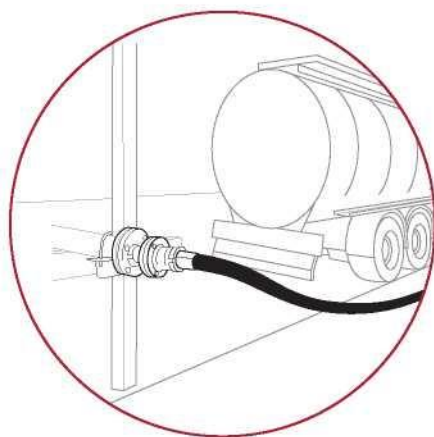



## NGXM Series – Next Generation Marine Break-Away

The TODO NGXM Series Break-Away again takes the principles of the engineered NGX Series and makes the product suitable for offshore applications. The addition of five load pins protects the break pins against lateral forces (i.e. tidal and wave movement), resulting in a high performance Break-Away that will only separate due to an overload in straight pull force.



### Technical Data

Sizes:	2" (DN50) - 6" (DN150)
Materials:	Stainless Steel (316L)
Seals:	Viton® (FKM) as standard. Wide range of other materials to suit many applications
Working Temperature:	-20°C (-4°F) - +80°C (176°F)
Working Pressure:	Up to 40 bar (580 psi)
Test Pressure:	Up to 60 bar (870 psi)
Possible Break Angle:	Straight pull only
End connections:	NPT / BSP / PN10/16 / PN25/40 / ANSI 150 / ANSI 300 / TTMA Others available on request

Viton® is a registered trademark of DuPont Performance Elastomers



# TODO

## BCR Series – Collar Release Break-Away

The Collar Release Break-Away is specifically designed for loading arm protection. Its design ensures a safe and reliable break point when the loading arm exceeds its predetermined working envelope. The safety cable, attached to the Collar Release Break-Away via the loading arm, ensures that there is no over-extension by activating and preventing damage.

At the point prior to over-extension, the safety cable pulls on the retaining collar of the Break-Away, releasing the clamps and allowing the collar to spring open. Once released, the spring loaded pistons inside the two halves are activated, closing off the two ends, stopping product flow, with minimal spillage, and preventing damage to the loading arm.



### Benefits of TODO BCR Series Collar Release Break-Away Couplings

- Same excellent flow rate / low pressure drop as the FGX Series
- No break pins
- Shielded spring design
- Operates independently of shut off safety systems
- Easy to reset on site
- Wide range of product variants
- High quality, high reliability



### Technical Data

Sizes: 2" (DN50) - 3" (DN80)

Materials: Stainless Steel (316L)

Seals: Viton® (FKM) as standard.

Wide range of other materials to suit many applications

Working Temperature: -20°C (-4°F) - +80°C (176°F)

Working Pressure: Up to 40 bar (580 psi)

Test Pressure: Up to 60 bar (870 psi)

End connections: NPT / BSP / PN10/16 / PN25/40 / ANSI 150 / ANSI 300

Others available on request

Viton® is a registered trademark of DuPont Performance Elastomers

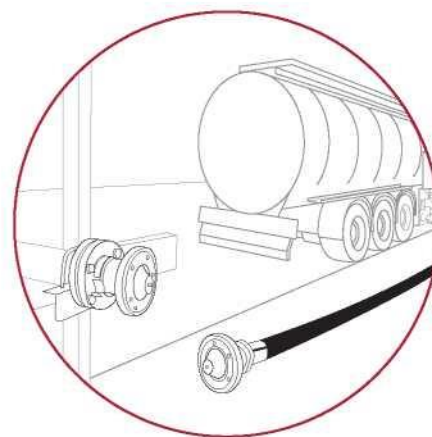
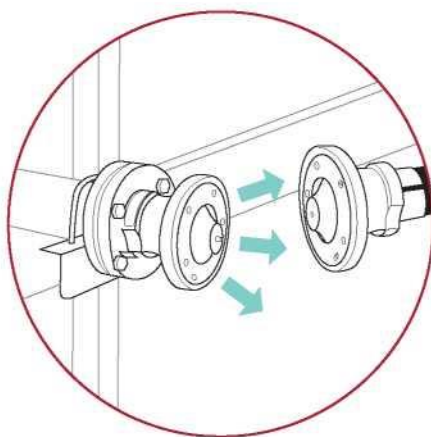
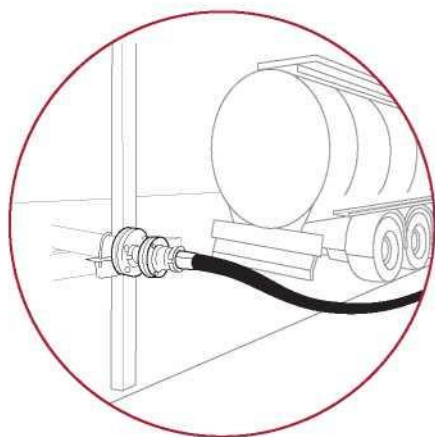



## Connection Type and Working Pressure

BA Size / in	Material	Units	Connection Type							
			NPT	BSP	PN10/16 Flange	PN25/40 Flange	ANSI 150	ANSI 300	Weld Ends	TTMA Flange
2	Stainless Steel	Bar	40	40	16	40	16	40	40	X
		psi	580	580	232	580	232	580	580	
	Aluminium	Bar	10	10	10	10	10	10	10	X
		psi	145	145	145	145	145	145	145	
3	Stainless Steel	Bar	40	40	16	40	16	40	40	16
		psi	580	580	232	580	232	580	580	232
	Aluminium	Bar	10	10	10	10	10	10	X	10
		psi	145	145	145	145	145	145		145
4	Stainless Steel	Bar	25	25	16	25	16	25	25	16
		psi	363	363	232	363	232	363	363	232
	Aluminium	Bar	10	10	10	10	10	10	X	10
		psi	145	145	145	145	145	145		145
6	Stainless Steel	Bar	23	23	16	23	16	23	23	16
		psi	334	334	232	334	232	334	334	232
	Aluminium	Bar	10	10	10	10	10	10	X	10
		psi	145	145	145	145	145	145		145

NB – Where X is shown, the product is not available

## Certification and Approvals

All TODO Break-Aways are certified and approved to the following standards:

- **2014/68/EU** – Pressure Equipment Directive
- **2014/34/EU** – ATEX
- **BS EN ISO9001:2015** – Quality Management Systems



# Disconnection Data

## NGX, NGXM Break-Aways

2" (DN50)						
Break Pin Size Separation Force (kN)	Al			SS		
	2.5mm	3.0mm	3.5mm	2.5mm	3.0mm	3.5mm
Unpressurised	15.5	20	28	15.5	20	28
10 bar	13.5	18.5	25	13.5	18.5	25
25 bar	X	X	X	11	16	23
30 bar	X	X	X	10	14	22
35 bar	X	X	X	9	13	21
40 bar	X	X	X	8	11.5	19.5

3" (DN80)						
Break Pin Size Separation Force (kN)	Al			SS		
	2.5mm	3.0mm	3.5mm	2.5mm	3.0mm	3.5mm
Unpressurised	13	19.5	27	13	19.5	27
10 bar	7	15	22	7	15	22
25 bar	X	X	X	X	7	15.5
30 bar	X	X	X	X	3.5	13
35 bar	X	X	X	X	1	11
40 bar	X	X	X	X	X	8.5

4" (DN100)						
Break Pin Size Separation Force (kN)	Al (3-Pin)			SS (5-Pin)		
	2.5mm	3.0mm	3.5mm	2.5mm	3.0mm	3.5mm
Unpressurised	15.5	22.5	29.5	TBC	TBC	TBC
10 bar	6	12.5	21	TBC	TBC	TBC
25 bar	X	X	X	TBC	TBC	TBC
30 bar	X	X	X	X	X	X
35 bar	X	X	X	X	X	X
40 bar	X	X	X	X	X	X



# Break Forces – Straight Pull

## NGX, NGXM Break-Aways

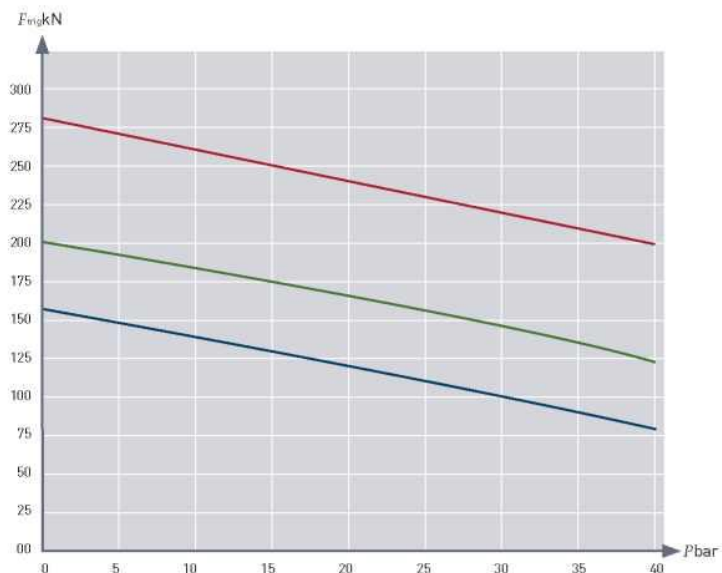

break forces 2" coupling

- 2.5mm pin
- 3.0mm pin
- 3.5mm pin

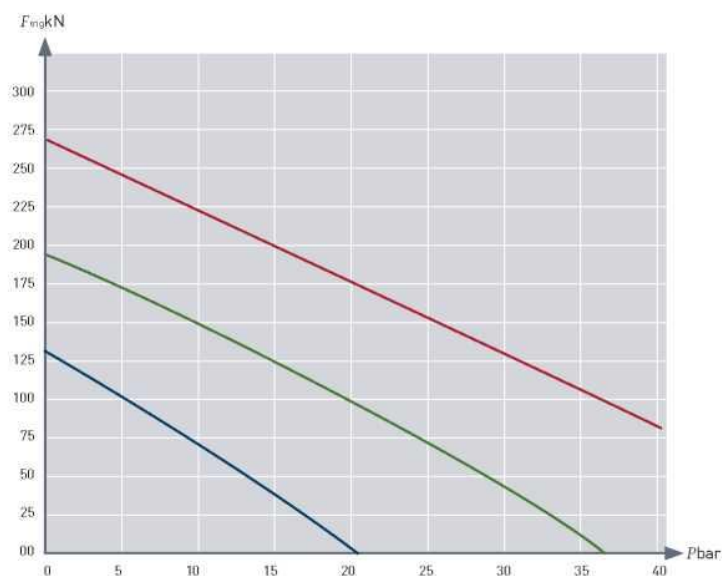

break forces 3" coupling

- 2.5mm pin
- 3.0mm pin
- 3.5mm pin

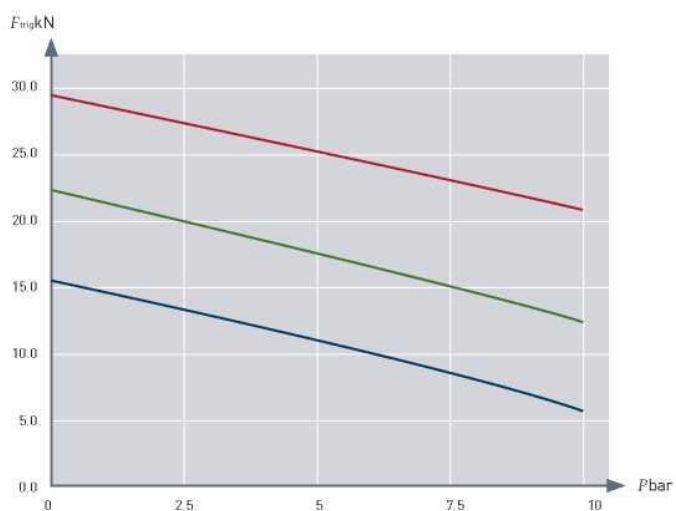

break forces 4" Al coupling

- 2.5mm pin
- 3.0mm pin
- 3.5mm pin



# Break Moment

## NGX Break-Aways

breakmoment [Nm]

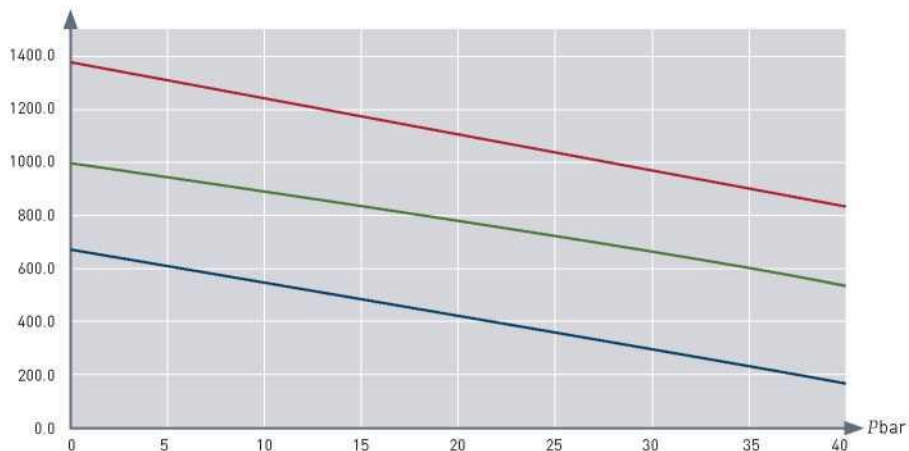

breakmoment [Nm]

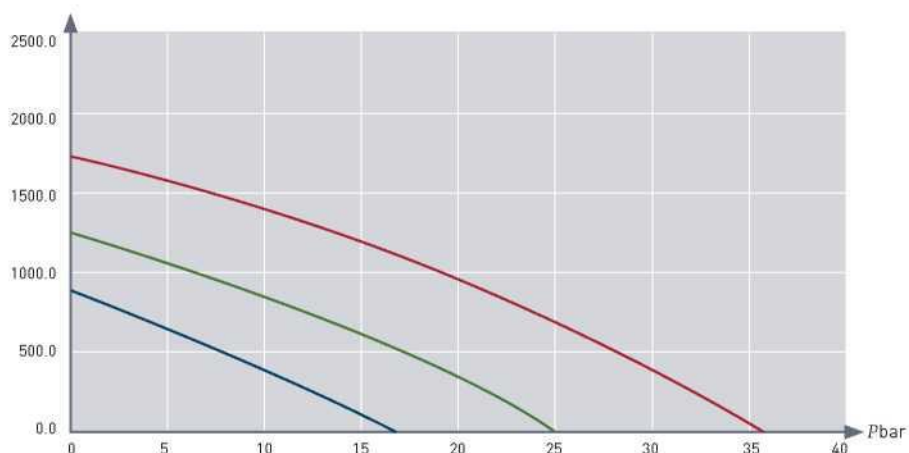

### 4" Al Break-Away 3 pins

2.5mm pin  
3.0mm pin  
3.5mm pin

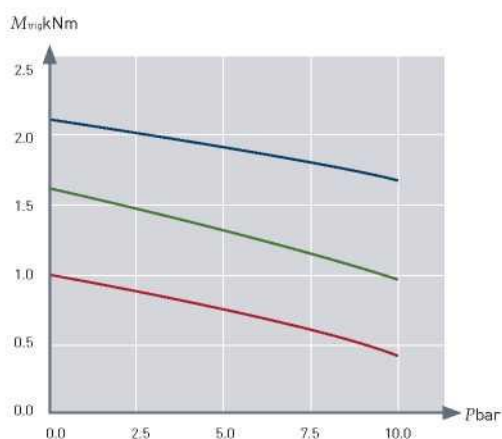

### 4" Break-Away 5 pins

4.5mm pin  
4.0mm pin  
3.5mm pin  
3.0mm pin  
2.5mm pin

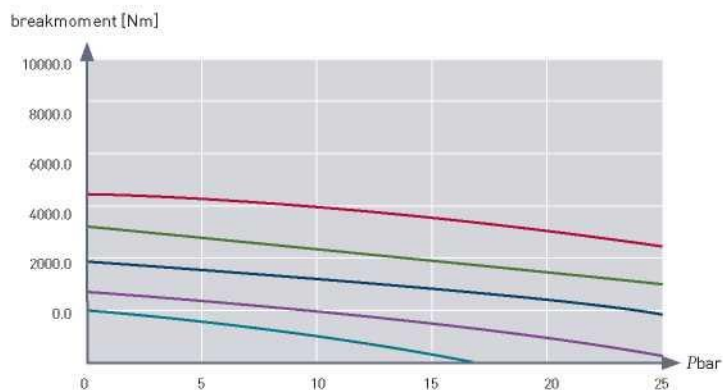

# Flow Capacity

## BCR Break-Aways

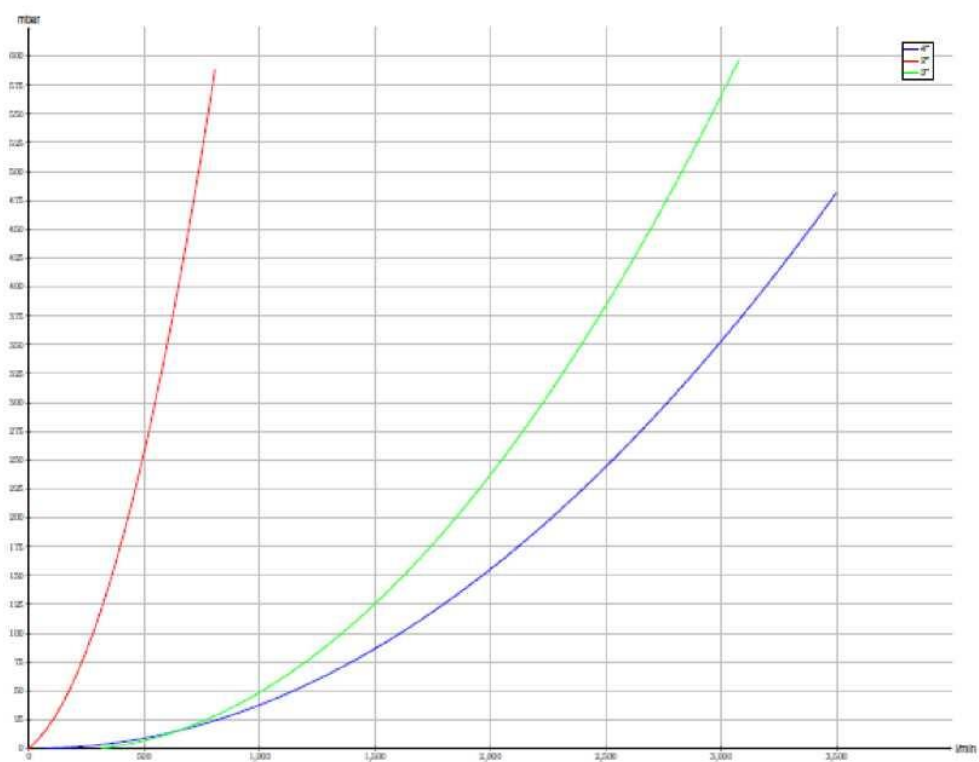

## NGX, NGXM Break-Aways 2" – 4"

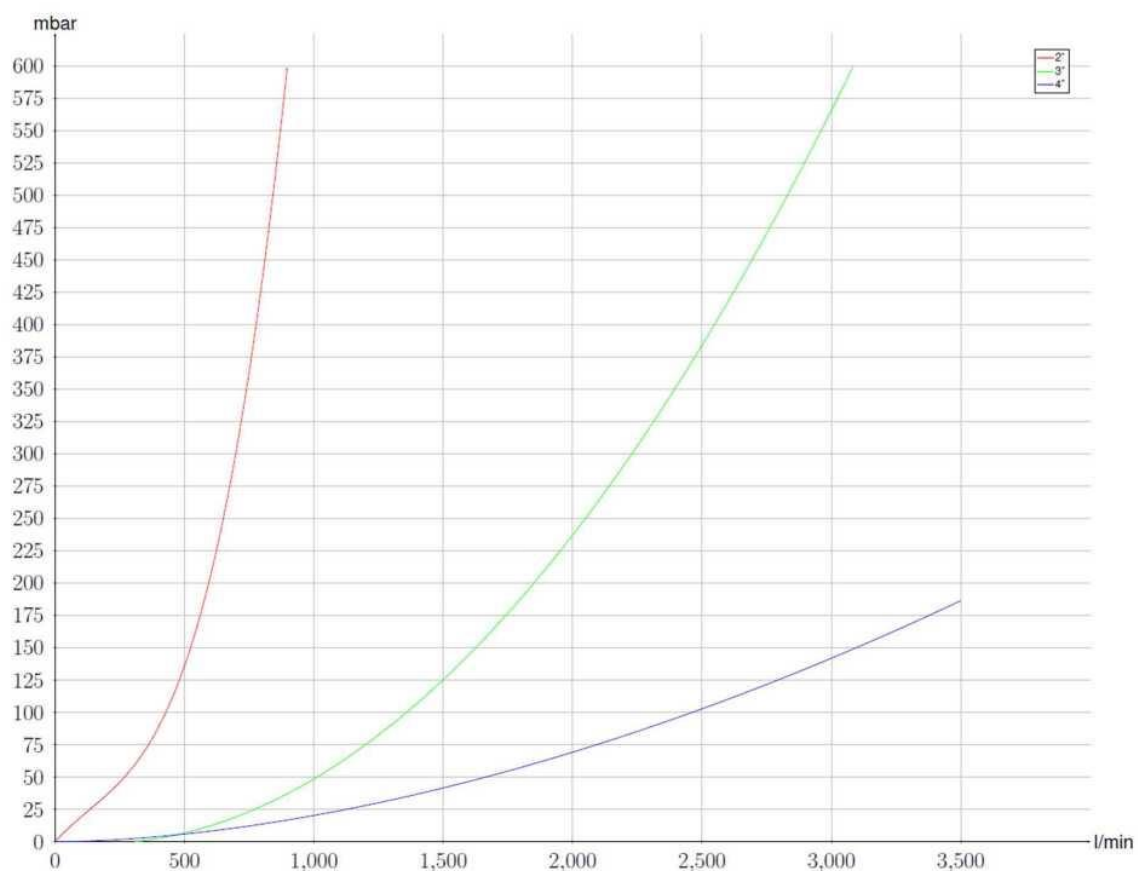

### NGX, NGXM Break-Away 6"

